

THIS DRAWING IS UNPUBLISHED. RELEASED FOR PUBLICATION  
 © COPYRIGHT - By - ALL RIGHTS RESERVED.

LOC		DIST		REVISIONS			
P	LTR	DESCRIPTION		DATE	DWN	APVD	
BD	48	F1	REVISED PER ECO-11-004835		11MAR11	RK	HMR

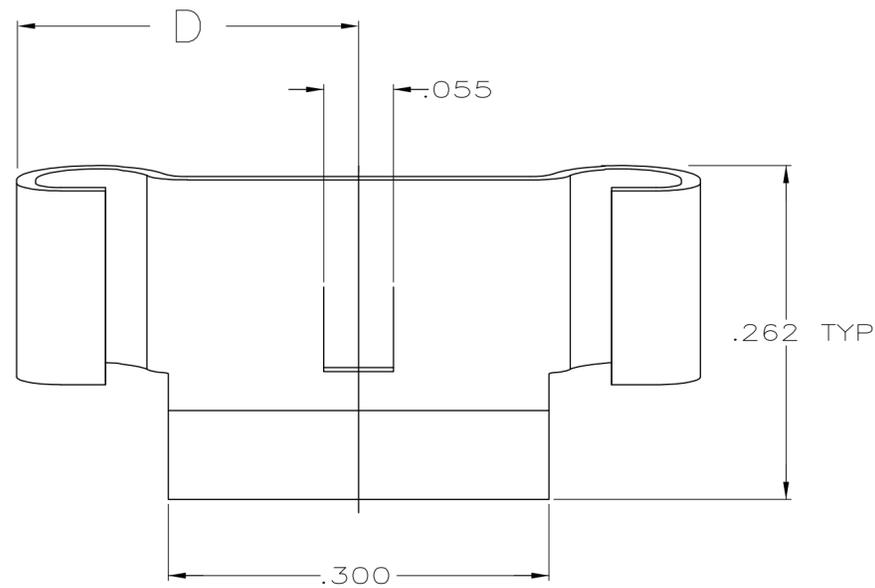
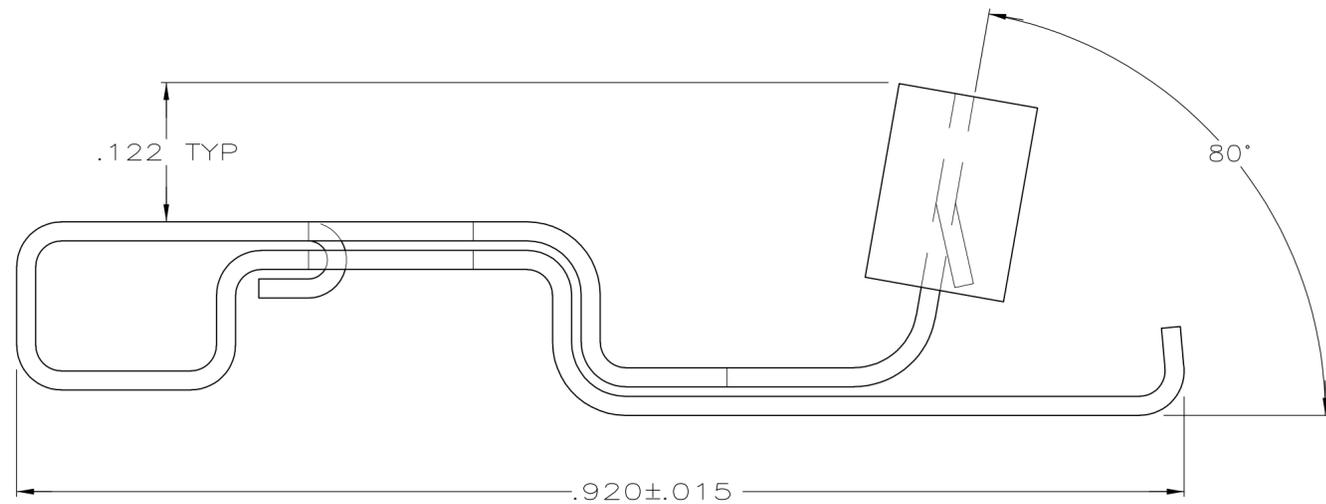
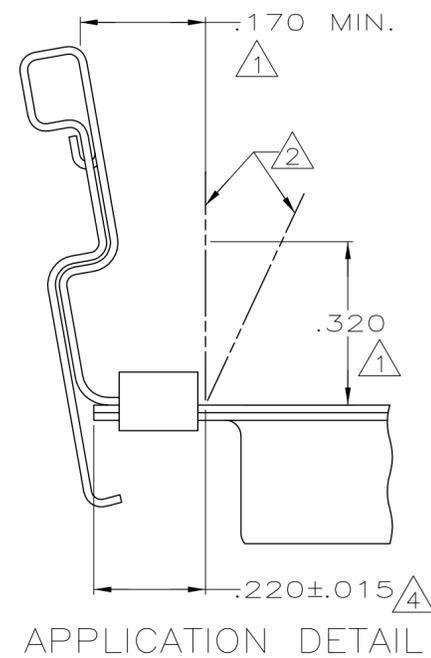
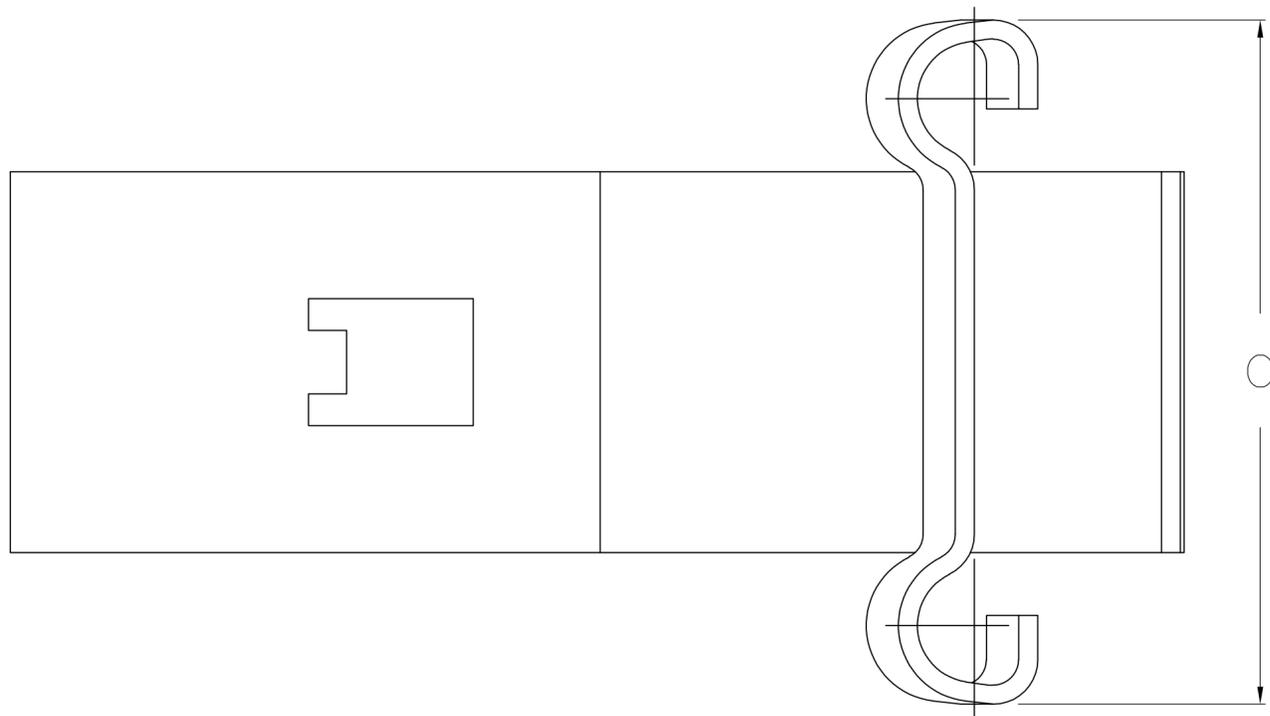

- 1 FOR SATISFACTORY OPERATION THESE DIMENSIONS MUST BE MAINTAINED, .170 DIMENSION SHOULD BE MEASURED AT HEIGHT OF .320 MIN.
- 2 SPRING LATCH ACCOUNTS FOR DESIGN VARIATIONS IN THE ENVELOPE OF POST MOLDED STRAIN RELIEFS.
- 3 WHEN ORDERING SPRING LATCHES SPECIFY NUMBER OF CONNECTORS, QUANTITY SHIPPED WILL BE BASED ON 2 SPRING LATCHES REQUIRED PER CONNECTOR.
- 4 MEASURED FROM END OF CONNECTOR FLANGE TO END OF TAB ON SPRING LATCH.

OBSELETE	D	C	KIT PACKAGING	PART NO
	.325	.650	BULK 3	745779-6
	.325	.650	2 PIECE UNIT	745779-5
	.270	.540	BULK 3	745779-3
	.270	.540	2 PIECE UNIT	745779-2

THIS DRAWING IS A CONTROLLED DOCUMENT.		DWN	J.GERACE	02-24-83																		
DIMENSIONS: INCHES		CHK	J.GERACE	02-24-83																		
TOLERANCES UNLESS OTHERWISE SPECIFIED:		APVD	R.LEGGETT	02-24-83																		
<table border="1"> <tr><td>0 PLC</td><td>±</td><td>-</td></tr> <tr><td>1 PLC</td><td>±</td><td>-</td></tr> <tr><td>2 PLC</td><td>±</td><td>-</td></tr> <tr><td>3 PLC</td><td>±</td><td>.010</td></tr> <tr><td>4 PLC</td><td>±</td><td>-</td></tr> <tr><td>ANGLES</td><td>±</td><td>3°</td></tr> </table>		0 PLC	±	-		1 PLC	±	-	2 PLC	±	-	3 PLC	±	.010	4 PLC	±	-	ANGLES	±	3°	PRODUCT SPEC	NAME
0 PLC	±	-																				
1 PLC	±	-																				
2 PLC	±	-																				
3 PLC	±	.010																				
4 PLC	±	-																				
ANGLES	±	3°																				
MATERIAL	FINISH	APPLICATION SPEC	NAME		SIZE	CAGE CODE	DRAWING NO	RESTRICTED TO														
STAINLESS STEEL	-	WEIGHT	-		A2	00779	C=745779	-														
CUSTOMER DRAWING				SCALE	10:1	SHEET	1 of 1	REV	F1													